

2. Physical Layer

2.1 Definition

2.2 Mechanical, Electrical and Functional Specifications

2.3 Transmission Techniques, Modulation, Multiplexing

2.4 Physical Media

2.5 Examples: V.24, ADSL

2.1 Definition of the Physical Layer

ISO-Definition

The physical layer defines **mechanical, electrical, functional and procedural** properties, in order to establish, hold and tear down a physical connection between Data Terminal Equipment (DTE) and Data Circuit-Terminating Equipment (DCE).

The physical layer provides the transmission of a transparent bit stream between data link layer entities by physical connections. A physical connection may allow the transmission of a bit stream in duplex mode or half-duplex mode.

Properties of the Physical Layer

- mechanical:** Dimensions of connectors, assignment of pins, etc. e.g. ISO 4903: “Data Communication – 15 pin DTE/DCE interface connector and pin assignment”
- electrical:** Voltage levels, etc., e.g. CCITT X.27/V.11: “Electrical characteristics for balanced double-current interchange for general use with integrated circuit equipment in the field of data communication”
- functional:** Classification of functions (which pin has which function: data, control, timing, ground), e.g. CCITT X.24: “List of definitions for interchange circuits between DTE and DCE on public data networks”
- procedural:** Rules (procedures) for the use of the interface, e.g. CCITT X.21: “Interface between DTE and DCE for synchronous operation on public data networks”

2.2 Mechanical, Electrical and Functional Specification

Mechanical specification:
geometry of connectors

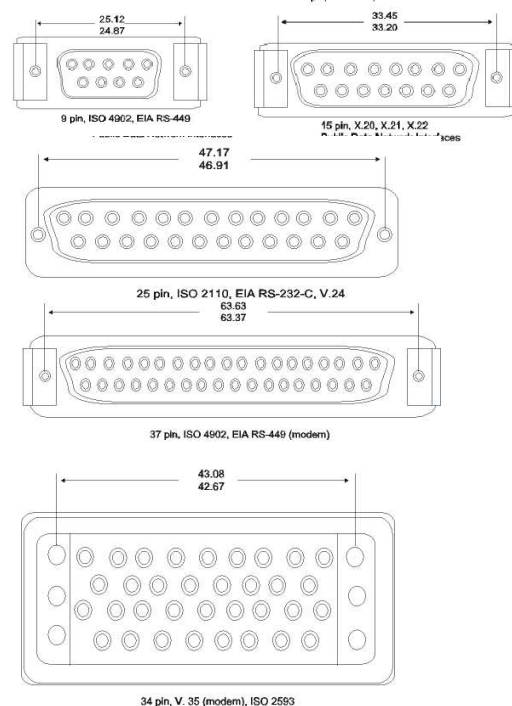

Electrical Properties: CCITT V.28 (EIA RS-232-C)

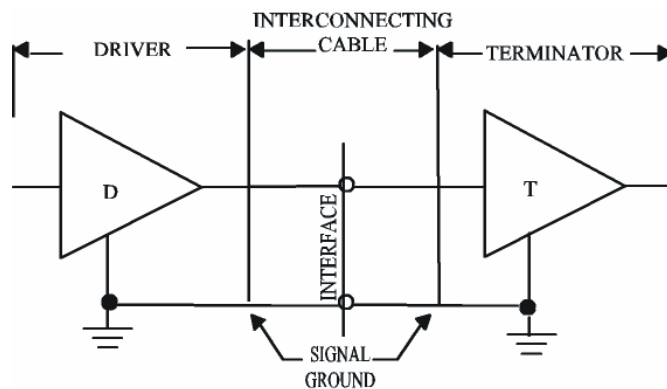

- For **discrete** electronic components
- One conductor per circuit, plus a common ground for both directions
- Bit rate limited to 20 kbit/s
- Distance limited to 15 m
- Produces substantial cross modulation

CCITT V.10/X.26 (EIA RS-423-A)

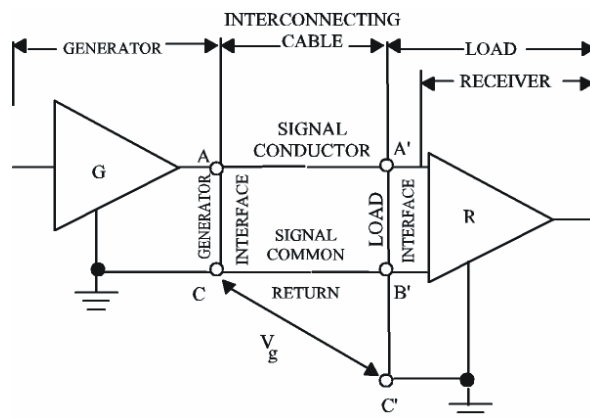

- For IC components (integrated circuits)
- One conductor per circuit, plus one common ground for each direction
- Bit rate up to 300 kbit/s
- Distance up to 1000 m at 3 kbit/s or up to 10 m at 300 kbit/s
- Reduced cross modulation

CCITT V.11/X.27 (EIA RS-422-A)

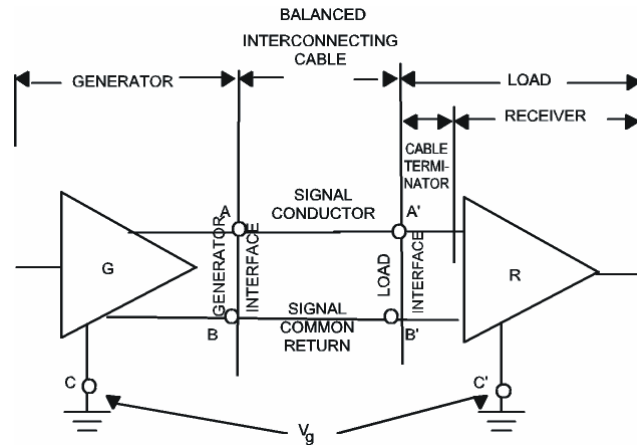

- For IC components (integrated circuits)
- Two conductors per circuit
- Bit rate up to 10 Mbit/s
- Distance up to 1000 m at 100 kbit/s or up to 10 m at 10 Mbit/s
- Minimal cross modulation

Functional Properties

The functions of the X.21 pins

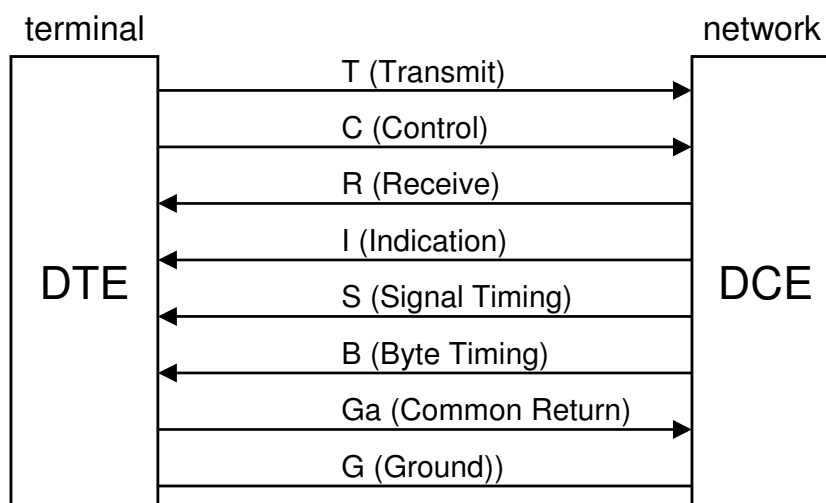

Functional/Procedural Specification in X.21

(in analogy to the telephone)

step	C	I	event analog to telephone	DTE sends on T	DCE sends on R
0	off	off	idle	T=1	R=1
1	on	off	DTE picks up the handset	T=0	
2	on	off	DCE sends dial tone		R="+++..+"
3	on	off	DTE dials telephone number	T=address in ASCII	
4	on	off	remote telephone rings		R=call progress signal
5	on	on	remote telephone answers		R=1
6	on	on	dialog (data transfer)	T=data	R=data
7	off	on	DTE says goodbye	T=0	
8	off	off	DCE says goodbye		R=0
9	off	off	DCE hangs up		R=1
10	off	off	DTE hangs up à idle	T=1	

Local Interface vs. Long-Distance Line

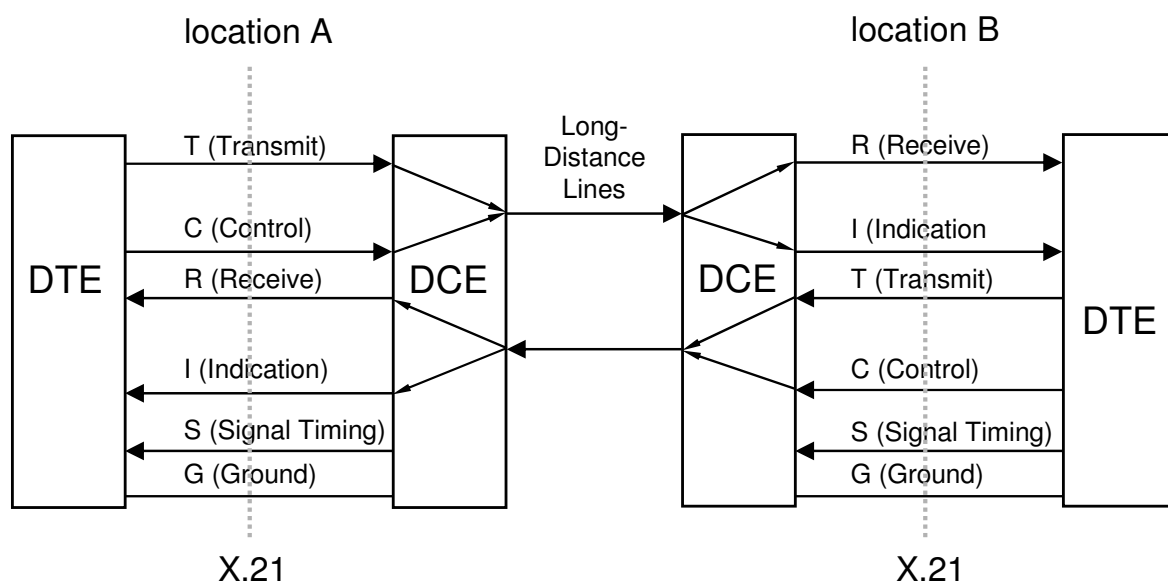

The number of conductors on the long-distance lines is not necessarily the same as the number of conductors at the DCE/DTE interface!

2.3 Transmission Techniques, Modulation, Multiplexing

Signal Transmission

Example: telephone, analog signals

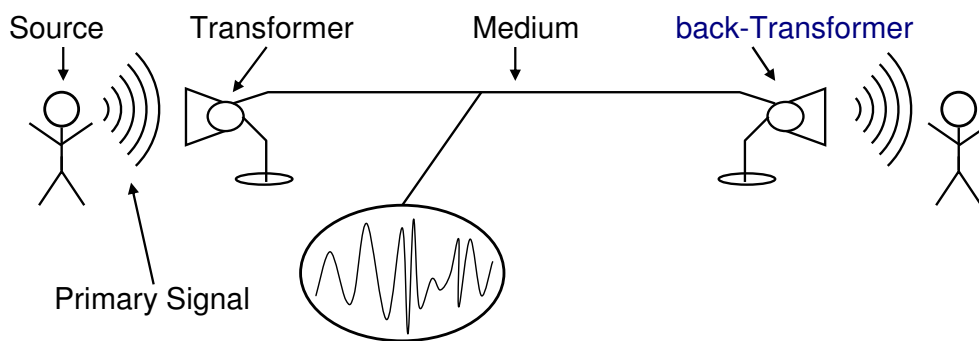

The primary signal (here acoustic) is converted by a transformer into an electrical (here analog) signal and changed back by a back-transformer. From here on, we will assume that the primary signal on the source side is electrical and that the primary signal on the receiver side is electrical as well. The transmission signal may also be electrical, with the same or other characteristics as the primary signal, but it could also be optical, etc.

Signals (1)

A **signal** is the physical representation of data.

Signal parameters are the physical characteristics of a signal that are used to represent the data.

For a time-dependent signal the value of the signal parameter S is a function of time:

$$S = S(t).$$

Signals (2)

Classification of time-dependend signals:

1. time-continuous, value-continuous signals
2. time-discrete, value-continuous signals
3. time-continuous, value-discrete signals
4. time-discrete, value-discrete signals

Is an exact signal value available at any given time?

yes: time-continuous

no: time-discrete

Are all signal values within the range of values permitted?

yes: value-continuous

no: value-discrete

Classes of Signals

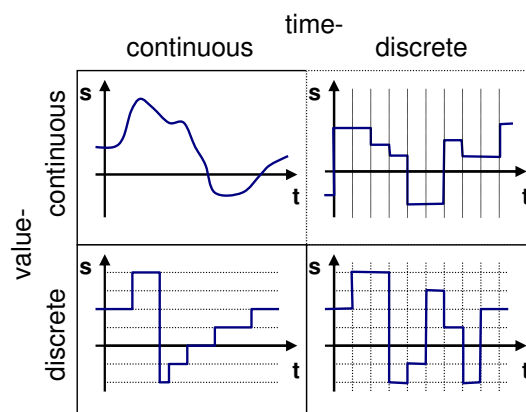

Examples

- value- and time-continuous: the analog telephone
- value-continuous, time-discrete: a process control application with periodical measurements of analog values
- value-discrete, time-continuous: continuous transmission of digital signal values
- value- und time-discrete: digital values with a fixed sampling rate

Basic Transmission Techniques (1)

- Digital input, digital transmission: **digital line coding**
- Digital or analog input, analog transmission: **modulation techniques**
- Analog input, digital transmission: **Digitization, Pulse Code Modulation**

Basic Transmission Techniques(2)

Analog and Digital Transmission:

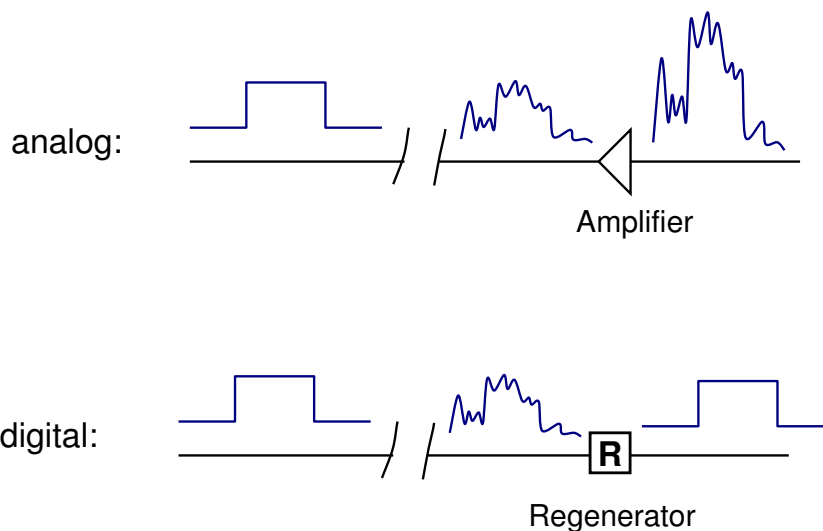

Digital Input, Digital Transmission

Modern digital transmission techniques use broadband techniques at very high bitrates (PCM technique, local area networks, etc.)

Desirable properties:

- No DC component at the physical level
- Recovery of the clock out of the arriving signal (self-clocking signal codes)
- Detection of transmission errors already at the signal level

Signal Encoding, Line Encoding, Transmission Code:

The mapping of a digital data element to a (possibly different) digital signal element is called **signal coding** or **line coding**. The resulting time-discrete and value-discrete signal codes are called **line codes** or **transmission codes**.

Important Digital Line Codes (1)

Non-Return to Zero - Level (NRZ-L)

- 1 = high voltage level
- 0 = low voltage level

Non-Return to Zero - Mark (NRZ-M)

- 1 = transition at the beginning of the interval
- 0 = no transition at the beginning of the interval

Non-Return to Zero - Space (NRZ-S)

- 1 = no transition at the beginning of the interval
- 0 = transition at the beginning of the interval

Return to Zero (RZ)

- 1 = rectangular pulse at the beginning of the interval
- 0 = no rectangular pulse at the beginning of the interval

Important Digital Line Codes (2)

Manchester Code (Biphase Level)

- 1 = transition from high to low in the middle of the interval
- 0 = transition from low to high in the middle of the interval

Biphase-Mark

- Always a transition at the beginning of the interval.
- 1 = another transition in the middle of the interval
- 0 = no transition in the middle of the interval

Biphase-Space

- Always a transition at the beginning of the interval.
- 1 = no transition in the middle of the interval
- 0 = another transition in the middle of the interval

Important Digital Line Codes (3)

Differential Manchester-Code

- Always a transition in the middle of the interval.
- 1 = no transition at the beginning of the interval
- 0 = additional transition at the beginning of the interval

Delay Modulation (Miller)

- Transition at the end of the interval if followed by a 0
- 1 = transition in the middle of the interval
- 0 = no transition if followed by a 1

Bipolar

- 1 = rectangular pulse in the first half of the intervall, alternating polarity
- 0 = no rectangular pulse

Differential Line Codes

Differential Encoding: We do not encode the *absolute* data value of the bit but the value *in relation to the preceding bit value*.

NRZ - M (Mark), NRZ - S (Space)

NRZ-M: change of the signal (transition to the opposite signal value) to encode a data value of “1”.

NRZ-S: change of the signal value to encode a data value of “0”.

Advantage over NRZ-L: On a noisy line signal **changes** are easier to detect than signal **levels** (which have to be compared with a threshold value).

Disadvantages of all NRZ codes: DC component and **no clock signal between transmitter and receiver**.

Biphase Codes

Biphase line codes have at least one signal change per bit interval and at most two signal changes per bit interval.

Advantages

- Easy synchronisation (clocking) of the receiver since there is always a “pulse edge“ to trigger the receiver
- No DC component in the signal
- Some error detection at the signal level (physical level) possible: missing transitions can be recognized easily

Disadvantage

- Twice the number of rectangular pulses for the same bit rate! Requires a better line quality for the same bit rate.

Bit Rate and Baud Rate

Bit rate

Number of bits (binary data values) transmitted per second.

Baud rate

Number of rectangular pulses per second on the line.

Bipolar Code

The bipolar code is an example for a line coding with more than two signal values (here: a tertiary signal).

The value “1” is represented alternatingly by a positive or negative pulse in the first half of the bit interval. Therefore there is no DC component.

The bipolar code is also called **AMI** (Alternate Mark Inversion).

Examples for Digital Line Codes

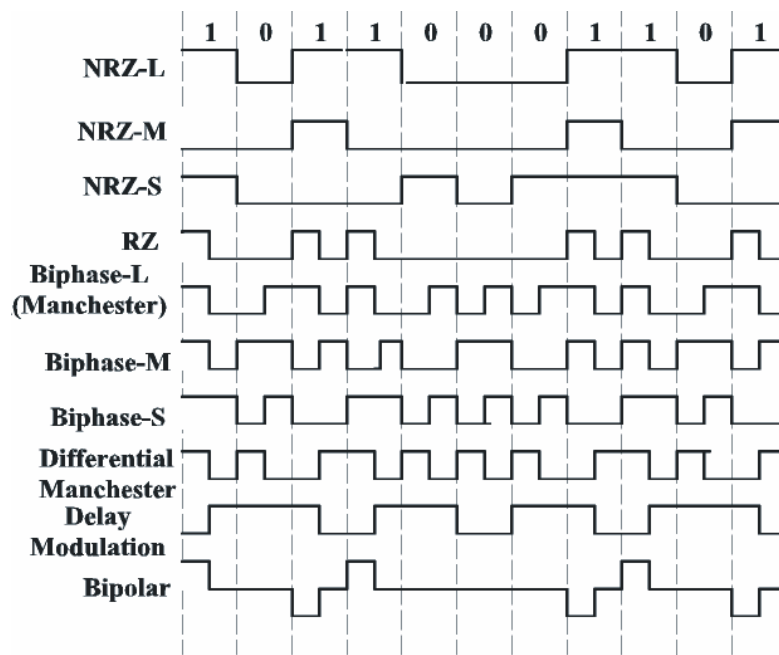

Digital/Analog Input, Analog Transmission

Modulation: encodes digital or analog input data on an *analog* carrier signal

Modem: Modulator-Demodulator

Example: transmission of digital data over the analog telephone network

Modulation methods

- Amplitude Modulation (AM)
- Frequency Modulation (FM)
- Phase Modulation (PM)

Modulation Methods

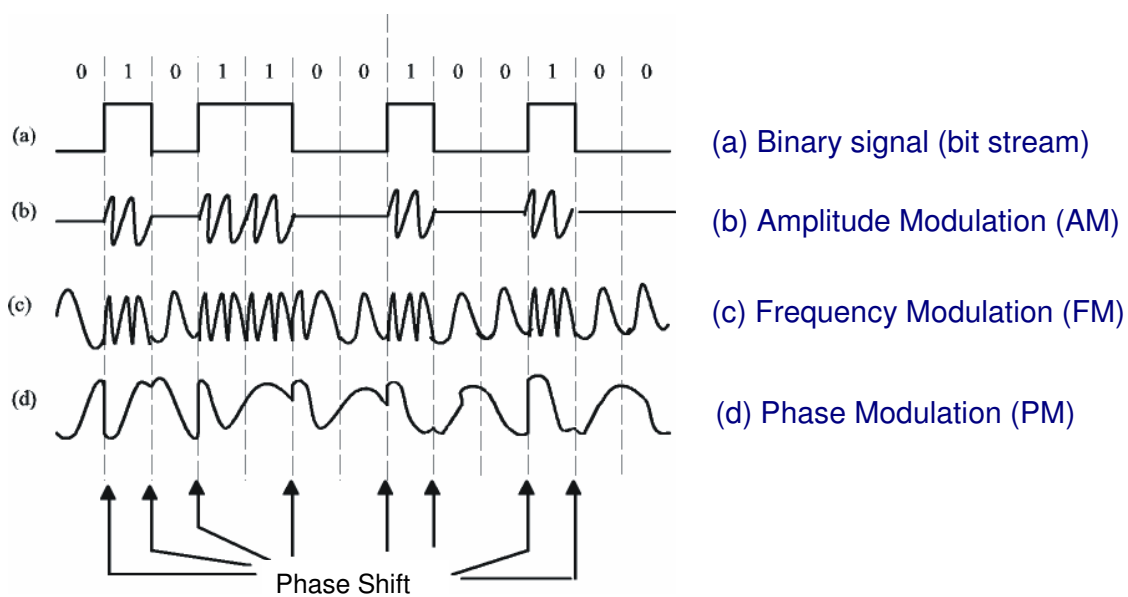

Multiplexing

Transmission path

Physical transport system for signals (e.g., cable)

Transmission channel

Abstraction of a transmission path for a signal stream.

Often, multiple transmission channels are operated in parallel over one transmission path. The mapping of multiple channels on one path is called **multiplexing**.

Frequency Division Multiplexing

Broadband transmission paths allow the allocation of several transmission channels to different frequency bands: the available frequency range is subdivided into a set of frequency bands, and a transmission channel is assigned to each band (**frequency division multiplexing**, FDM).

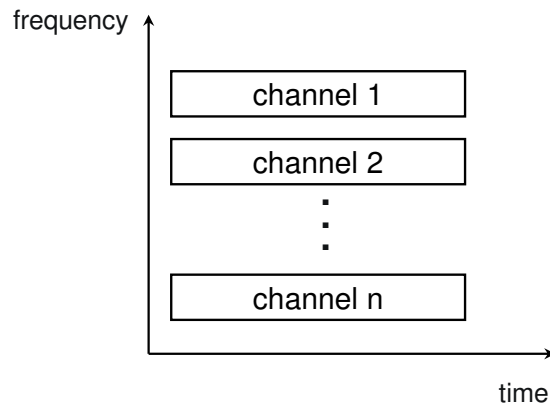

Frequency Multiplexing

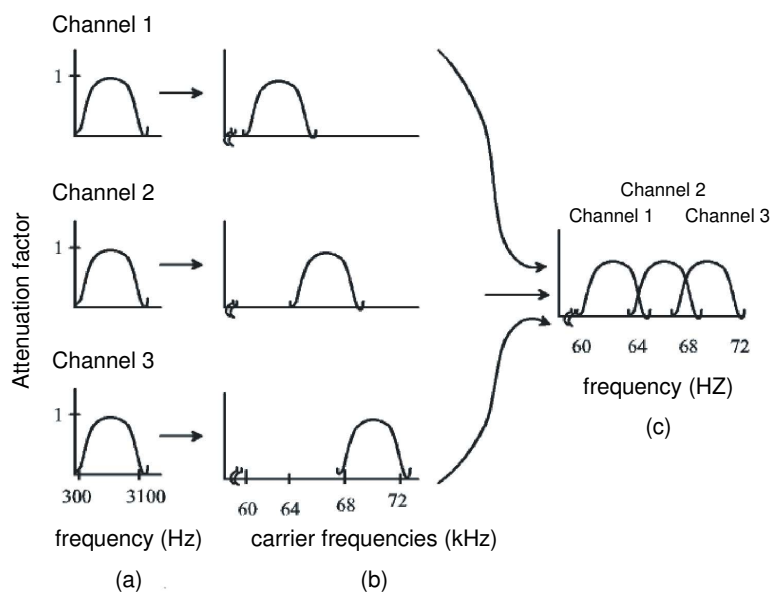

Time Division Multiplexing

The entire available bandwidth is made available to one channel at a time, allowing very high baud rates. The channels take turns in accessing the physical medium. Each channel receives one **time slot** per period (**time division multiplexing**, TDM).

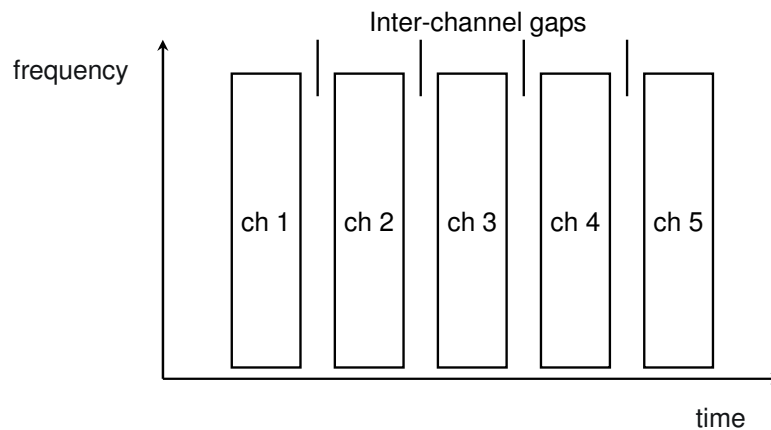

Synchronous Time Division Multiplexing

Time division multiplexing is applicable only to time-discrete signals (preferably to time- and value-discrete signals = digital signals).

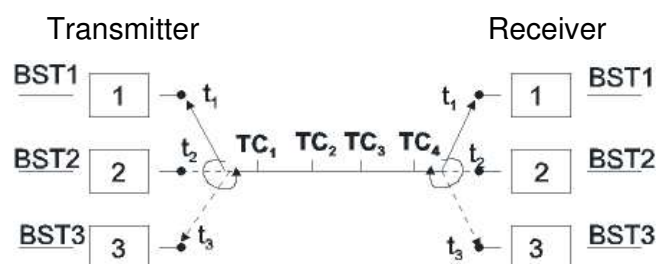

With **synchronous time division multiplexing**, time is divided into fixed-size periods. Each of the n transmitters is assigned one time slot (time slice) TC_1, TC_2, \dots, TC_n per period. Transmitters and detectors at the receiver run at the same clock speed (in synch).

Asynchronous Time Division Multiplexing

The transmission path is not assigned to the transmitters in a static way, but by need. Thus the receiver cannot derive the association of a piece of data with a channel from timing anymore. Therefore a *channel id* is now required for each data block (packet, cell).

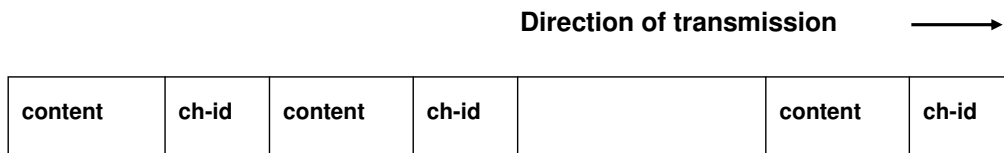

Asynchronous time division multiplexing is also called **statistical time division multiplexing (STDM)**.

Comparison of Multiplexing Methods

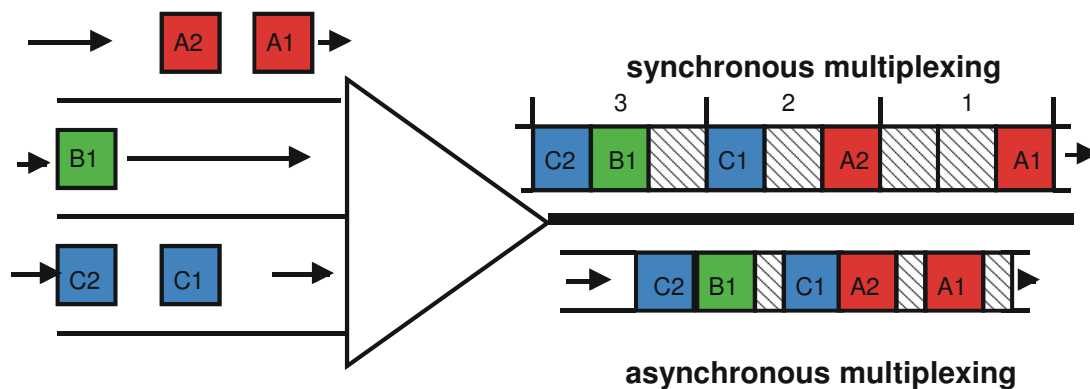

Analog Input, Digital Transmission (1)

The transmission of analog data over a digital transmission paths requires the **digitization** of the data.

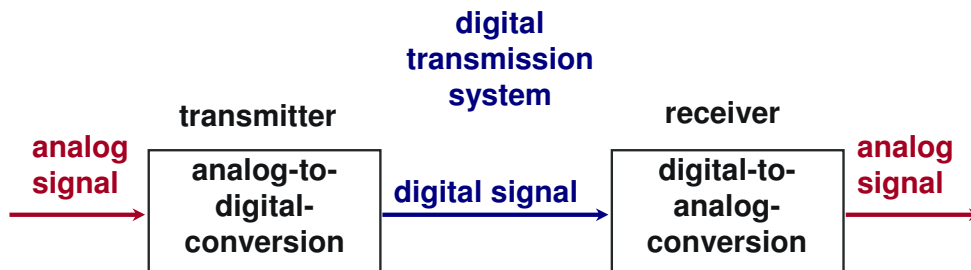

Analog Input, Digital Transmission (2)

A/D- and D/A conversion for transmission of analog signals on digital transmission systems.

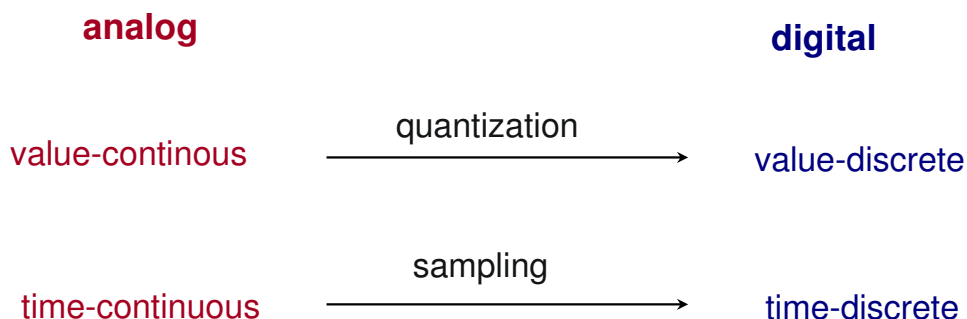

Advantages of Digital Transmission

- Low error rate
 - no noise introduced by amplifiers
 - no accumulation of noise over long distances
- Easier Time Division Multiplexing (TDM)
- Digital circuits are less expensive.

As a consequence, the digital storage and transmission of analog signals becomes more and more popular:

- Audio CD
- Video on DVD
- DAB (Digital Audio Broadcast)
- DVB (Digital Video Broadcast, digital TV)
- and many more...

Sampling

In order to convert a time-continuous signal into a time-discrete signal, the input is **sampled**.

In most practical cases sampling is periodic.

Sampling Theorem of Nyquist

For an error-free reconstruction of the analog signal, a minimum sampling rate f_A is necessary. The higher the frequencies in the analog data are, the higher the sampling frequency must be. For noise-free channels the Sampling Theorem of Nyquist applies:

Sampling Theorem

The sampling rate f_A must be twice as high as the highest frequency in the signal f_S :

$$f_A = 2 * f_S$$

Sampling at Different Frequencies

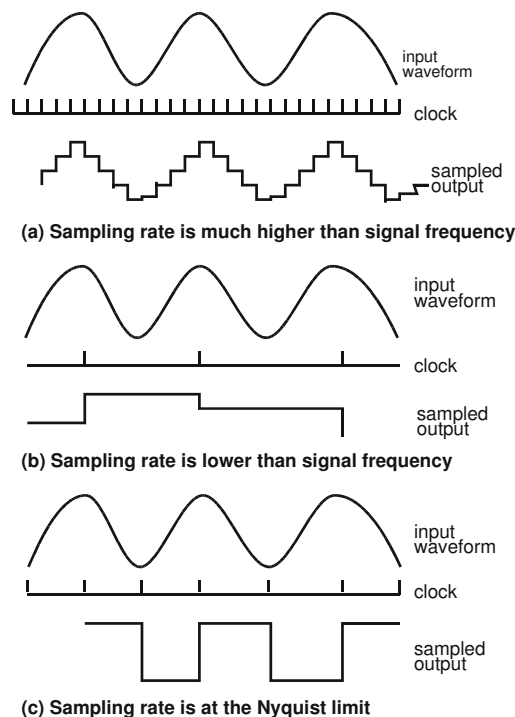

Quantization

The amplitude range of the analog signal is subdivided into a finite number of intervals (quantization intervals). To each interval a discrete value is assigned. Since all analog signal values belonging to one quantization interval are assigned to the same discrete value, there will be a **quantization error**.

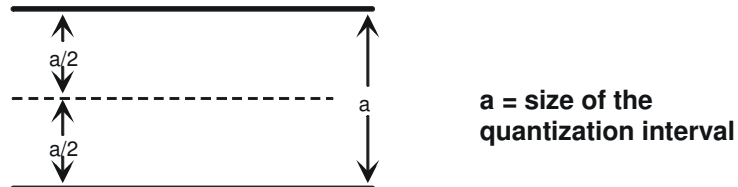

Back transformation

At the receiver the original analog value is reconstructed (digital-to-analog conversion). The maximum quantization error will be $a/2$.

Binary Encoding

Each quantization interval is represented by a binary value which is transmitted over the channel.

In many practical cases the binary representation is just the interval number.

Fundamental Quantization Trade-off

The finer the quantization interval, the smaller the quantization error, but the more bits we will need per sample.

In other words: the better the quality we need, the higher the bit rate.

Illustration of Sampling, Quantization and Encoding

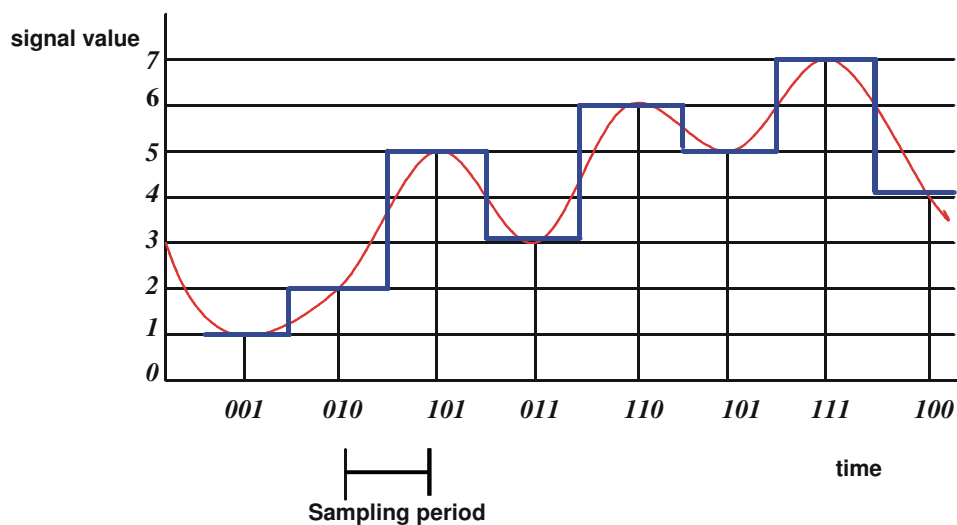

Pulse Code Modulation (PCM)

The combination of the steps

- sampling
- quantization
- encoding

and the representation of the resulting bit stream as a digital baseband signal is called **pulse code modulation (PCM)**.

The A/D conversion (sampling, quantization and coding) as well as the D/A conversion is performed by a so-called **CODEC** (Coder/Decoder).

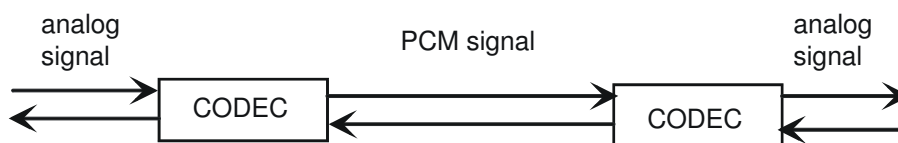

PCM Telephone Channels

The ITU-T (formerly CCITT) has standardized two PCM transmission systems many years ago.

Starting point: the analog CCITT telephone channel

Frequency band: 300 - 3400 Hz (range of human speech)

Bandwidth: 3100 Hz

Sampling rate: $f_A = 8 \text{ kHz}$

Sampling period: $T_A = 1/f_A = 1/8000 \text{ Hz} = 125 \mu\text{s}$

The sampling rate selected by the ITU-T is somewhat higher than necessary according to Nyquist's sampling theorem: the maximum frequency of 3400 Hz would result in a sampling rate of 6800 Hz. There are technical reasons for the slightly higher sampling rate (noise, filter design, channel separation).

Amplitude Quantization

The number of quantization intervals was determined for speech communication for good comprehensibility of syllables. The ITU-T considered 256 quantization intervals to be optimal (empirically determined).

For binary encoding the 256 intervals require 8 bits.

The transmission speed (bit rate) for a PCM telephone channel is therefore:

$$\begin{aligned} \text{Bit rate} &= \text{sampling frequency} \quad \text{times} \quad \text{length of the codeword} \\ \text{kbit/s} &= 8000/\text{s} \quad \quad \quad \times \quad \quad \quad 8 \text{ bits} \\ &= 64 \text{ kbit/s} \end{aligned}$$

Nonlinear Quantization (1)

With linear quantization, all intervals are equal in size and independent of the current value of the signal.

However, turns out that humans perceive quantization errors (quantization noise) more clearly at small small amplitudes.

With **nonlinear quantization** the quantization intervals are larger for large signal amplitudes and smaller for small amplitudes.

The nonlinear mapping is performed by a **compressor** which is inserted into the signal path upstream of the quantizer. On the receiving side an **expander** inverts the operation.

Nonlinear quantization is usually based on a logarithmic curve. Technically, the mapping is approximated by linear sections in digital electronic circuits.

Nonlinear Quantization (2)

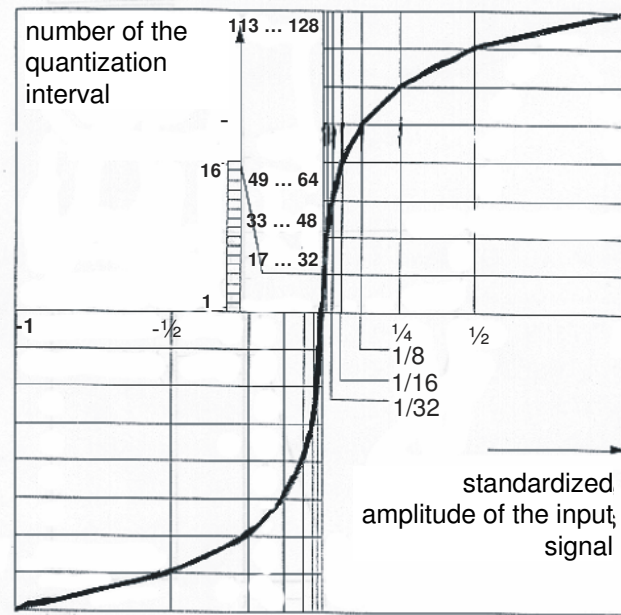

13-segment compressor curve

Delta Modulation

Usually the difference of the signal values between two sampling times is much smaller than the absolute value of the signal. **Delta modulation** takes advantage of this fact by **encoding signal differences**.

1 = increasing signal
0 = decreasing signal

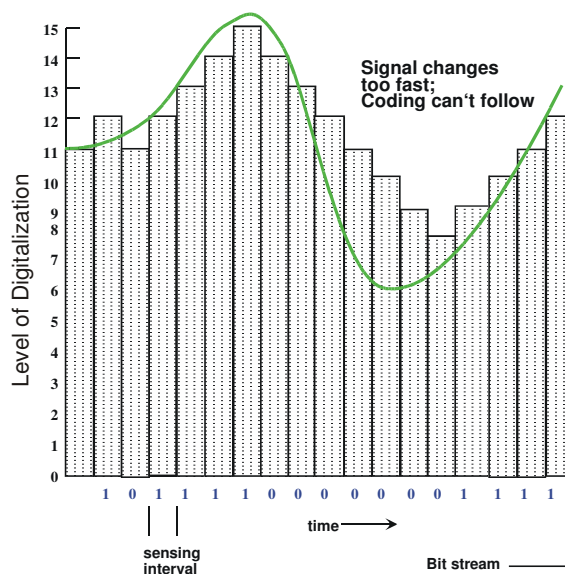

Differential PCM

Differential PCM is a technique in the middle between standard PCM (the encoding of absolute values) and delta modulation. More than one bit is used to encode the difference to the previous value, but fewer bits than with standard PCM.

Adaptive Differential PCM (ADPCM)

As with differential PCM, a small number of bits is used to encode value differences. However, the size of the quantization intervals is adapted dynamically to the variance in the amplitudes: at times when the amplitude varies widely, large quantization intervals are used; in periods of small changes, a finer granularity is used, reducing quantization noise in low-amplitude phases.

ADPCM with nonlinear quantization is widely used to represent audio in computers. A-law and μ -law are two popular examples.

Asynchronous vs. Synchronous Transmission

Asynchronous:

There is no common clock between transmitter and receiver.

Synchronous:

A clock pulse is transmitted over the line. It is used for the exact synchronization of the receiver.

Asynchronous Transmission (1)

- Transmitter and receiver have independent local clocks.
- NRZ-L is used as the line coding.
- An idle line corresponds to a continuous sequence of 1-bits.
- The “start bit” sets the line to 0. On the receiving side it starts the master clock of the receiver.
- One frame with 5 to 8 bits (= one character) is transmitted.
- The “stop bit” sets the line to 1 again. The “stop bit” lasts for 1, 1.5 or 2 normal bit intervals.

Asynchronous Transmission (2)

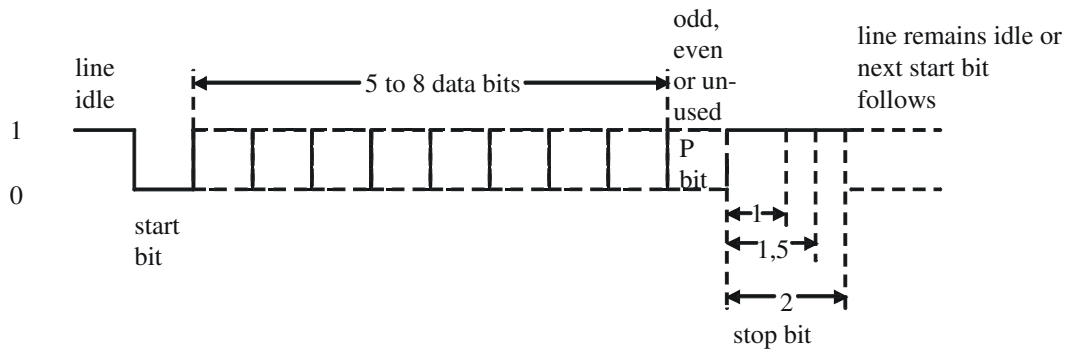

line coding for one character

Asynchronous Transmission (3)

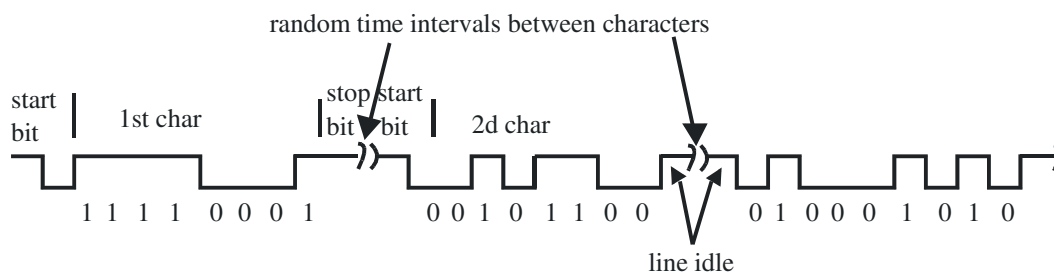

asynchronous bit stream

Asynchronous Transmission (4)

Effect of clock drift between sender and receiver

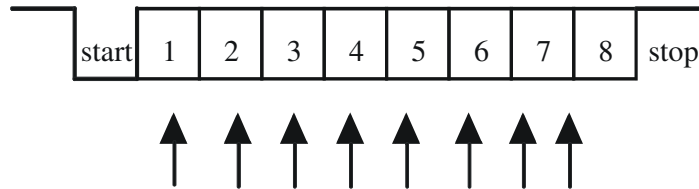

The receiver's clock is slightly faster. It samples bit 7 of the signal twice, leading to an incorrect value for bit 8.

Asynchronous Transmission (5)

Advantages

- No synchronization of the clocks needed
- The clock signal does not need to be transmitted over the line.
- Easy implementation

Disadvantages

- The clocks of sender and receiver may deviate. Therefore:
 - The frame size is very limited (typically a character of 7-8 bits).
 - The technique only is applicably at low data rates.
- Start and stop bits cause significant overhead. Example:
 - 7-bit ASCII characters as data
 - 1 parity bit
 - 1 start bit
 - 1 stop bitOnly 70% of the line capacity is available for user data!

Synchronous Transmission (1)

The clocks of the sender and the receiver are permanently synchronized.

The clock signal is either transmitted over a separate line (e.g., with X.21 by the service provider) or is extracted out of the line signal (e.g., with Manchester codes).

Synchronous Transmission (2)

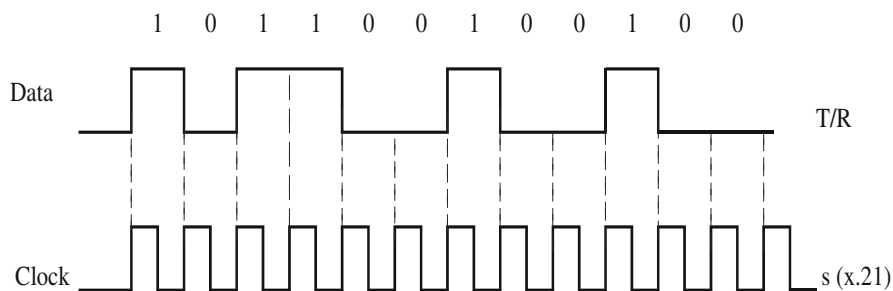

The data signal is read when the clock pulse drops from 1 to 0.