

2. Compression Algorithms for Multimedia Data Streams

- 2.1 Fundamentals of Data Compression
- 2.2 Compression of Still Images
- 2.3 Video Compression
- 2.4 Audio Compression

A Graduate Course on Multimedia Technology	© Wolfgang Effelsberg, Ralf Steinmetz	2. Compression, Part a	2a-1
--	---------------------------------------	------------------------	------

2.1 Fundamentals of Data Compression

Motivation: huge volume of the data

Text

1 page with 80 characters/line and 64 lines/page and 1 byte/char results in $80 * 64 * 1 * 8 = 40$ **kbit/page**

Still image

24 bits/pixel, 512 x 512 pixel/image results in $512 * 512 * 24 = 8$ **Mbit/image**

Audio

CD quality, sampling rate 44,1 KHz, 16 bits per sample results in $44,1 * 16 = 706$ **kbit/s stereo: 1,412 Mbit/s**

Video

Full-size frame 1024 x 768 pixel/frame, 24 bits/pixel, 30 frames/s results in $1024 * 768 * 24 * 30 = 566$ **Mbit/s**.
More realistic: 360 x 240 pixel/frame, 360 x 240 x 24 x 30 = **60 Mbit/s**

=> **Storage and transmission of multimedia streams require compression!!**

A Graduate Course on Multimedia Technology	© Wolfgang Effelsberg, Ralf Steinmetz	2. Compression, Part a	2a-2
--	---------------------------------------	------------------------	------

Principles of Data Compression

1. Lossless Compression)

- The original can be reconstructed perfectly
- Compression rates of 2:1 up to 50:1 are typical
- Example: Huffman-Coding

2. Lossy Compression

- There is a difference between the original object and the reconstructed object
- Physiological and psychological properties of the ear and eye are taken into account
- Higher compression rates are possible than with lossless compression (e.g. up to 100:1)

A Graduate Course on Multimedia Technology	© Wolfgang Effelsberg, Ralf Steinmetz	2. Compression, Part a	2a-3
---	--	---------------------------	------

Simple Lossless Algorithms: Pattern Substitution

Example 1: **ABC -> 1; EE -> 2**

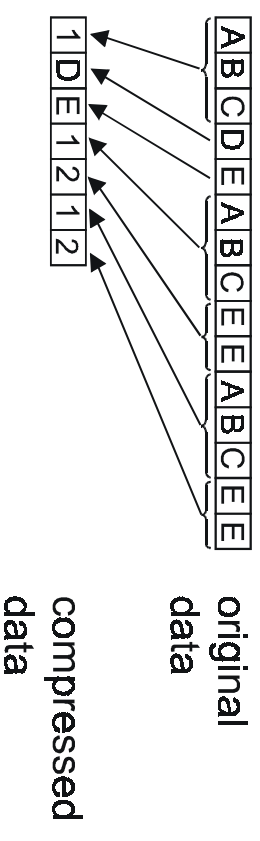

Example 2:

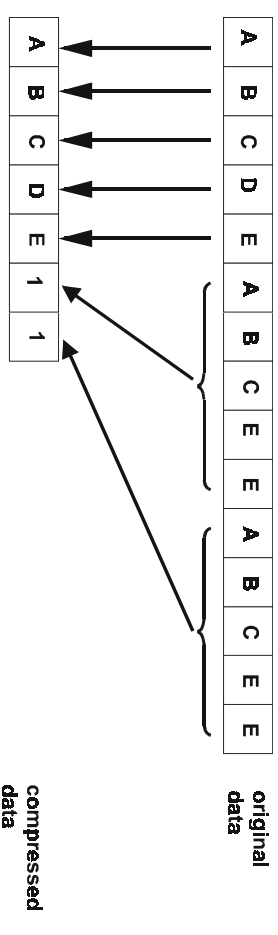

Note that both algorithms lead to the same compression rate in this example.

A Graduate Course on Multimedia Technology	© Wolfgang Effelsberg, Ralf Steinmetz	2. Compression, Part a	2a-4
---	--	---------------------------	------

Run Length Coding

Principle

Replace all repetitions of the same symbol in the text („runs“) by a repetition counter and the symbol.

Example

Text:

AAAABBBAABBBBCCCCCCDABCBAAABBBCCD

Encoding: 4A3B2A5B8C1D1A1B1C1B2A4B2C1D

As we can see, we can only expect a good compression rate when long runs occur frequently.

Examples in text documents are long runs of blanks, leading zeroes or strings of „white“ in gray-scale images.

A Graduate Course on Multimedia Technology	© Wolfgang Effelsberg, Ralf Steinmetz	2. Compression, Part a	2a-5
---	--	---------------------------	------

Run Length Coding for Binary Files

When dealing with binary files we are sure that a run of “1”s is always followed by a run of “0”s and vice versa. It is thus sufficient to store the repetition counters only!

Example

```
000000000000000000000000011111111111100000000 28 14 9
000000000000000000000000011111111111111000000 26 18 7
000000000000000000000000011111111111111110000 23 24 4
000000000000000000000000011111111111111111000 22 26 3
000000000000000000000111111111111111111111110 20 30 1
000000000000000000011111111000000000000000001 19 7 18 7
000000000000000000011111000000000000000000001 19 5 22 5
000000000000000000011100000000000000000000001 19 3 26 3
000000000000000000011100000000000000000000001 19 3 26 3
000000000000000000011100000000000000000000001 19 3 26 3
000000000000000000011100000000000000000000001 19 3 26 3
000000000000000000011100000000000000000000001 19 3 26 3
000000000000000000011100000000000000000000001 20 4 23 3 1
000000000000000000011100000000000000000000001 22 3 20 3 3
01111111111111111111111111111111111111111111 1 50
01111111111111111111111111111111111111111111 1 50
01111111111111111111111111111111111111111111 1 50
01111111111111111111111111111111111111111111 1 50
01111111111111111111111111111111111111111111 1 50
01100000000000000000000000000000000000000001 1 2 4 6 2
```

A Graduate Course on Multimedia Technology	© Wolfgang Effelsberg, Ralf Steinmetz	2. Compression, Part a	2a-6
---	--	---------------------------	------

Variable Length Coding

Classical character codes use the same number of bits for each character. When the frequency of occurrence is different for different characters, we can use fewer bits for frequent characters and more bits for rare characters.

Example

Code 1: A B C D E ...
 1 2 3 4 5 ... (binary)

Encoding of ABRACADABRA with constant bit length (=5 Bits):

```
00001000101001000000100011000010010000001
000101001000001
```

Code 2: A B R C D
 0 1 1 01 11

Encoding: 0 1 1 01 0 10 0 11 0 1
 01 0

A Graduate Course on Multimedia Technology	© Wolfgang Effelsberg, Ralf Steinmetz	2. Compression, Part a	2a-7
---	--	---------------------------	------

Delimiters

Code 2 can only be decoded unambiguously when delimiters are stored with the codewords. This can increase the size of the encoded string considerably.

Idea

No code word should be the prefix of another codeword! We will then no longer need delimiters.

Code 3:

A	1 1
B	0 0
R	0 1 1
C	0 1 0
D	1 0

Encoded string: 11000111110101110110001111

A Graduate Course on Multimedia Technology	© Wolfgang Effelsberg, Ralf Steinmetz	2. Compression, Part a	2a-8
---	--	---------------------------	------

Representation as a Trie

An obvious method to represent such a code as a TRIE. In fact, any TRIE with M leaf nodes can be used to represent a code for a string containing M different characters.

As two examples the figure on the next page shows two codes which can be used for ABRACADABRA. The code for each character is represented by the path from the root of the TRIE to that character where "0" goes to the left, "1" goes to the right, as is the convention for TRIES.

The TRIE on the left corresponds to the encoding of ABRACADABRA on the previous page, the TRIE on the right generates the following encoding:

01101001111011100110100

which is two bits shorter.

A Graduate Course on Multimedia Technology	© Wolfgang Effelsberg, Ralf Steinmetz	2. Compression, Part a	Za-9
---	--	---------------------------	------

Two Tries for our Example

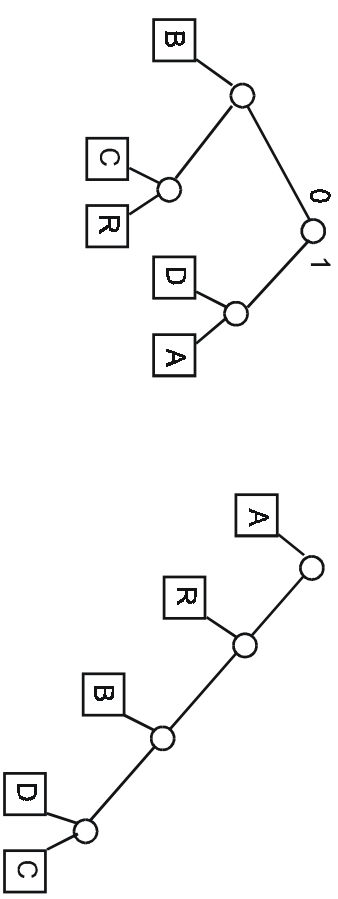

The TRIE representation guarantees that no codeword is the prefix of another codeword! Thus the encoded bit string can be uniquely decoded.

A Graduate Course on Multimedia Technology	© Wolfgang Effelsberg, Ralf Steinmetz	2. Compression, Part a	Za-10
---	--	---------------------------	-------

Huffman Code

Now the question arises how we can find the **best** variable-length code for given character frequencies (or probabilities). The algorithm that solves this problem was found by David Huffman in 1952.

Algorithm Generate-Huffman-Code

1. Determine the frequencies of the characters and mark the leaf nodes of a binary tree (to be built) with them.
2. Out of the tree nodes not yet marked as DONE, take the two with the smallest frequencies and compute their sum.
3. Create a parent node for them and mark it with the sum. Mark the branch to the left son with 0, the one to the right son with 1.
4. Mark the two son nodes as DONE. When there is only one node not yet marked as DONE, stop (the tree is complete). Otherwise, continue with step 2.

A Graduate Course on Multimedia Technology	© Wolfgang Effelsberg, Ralf Steinmetz	2. Compression, Part a	Za-11
---	--	---------------------------	-------

Huffman Code, Example

Probabilities of the characters:

$$p(A) = 0.3; p(B) = 0.3; p(C) = 0.1; p(D) = 0.15;$$

$$p(E) = 0.15$$

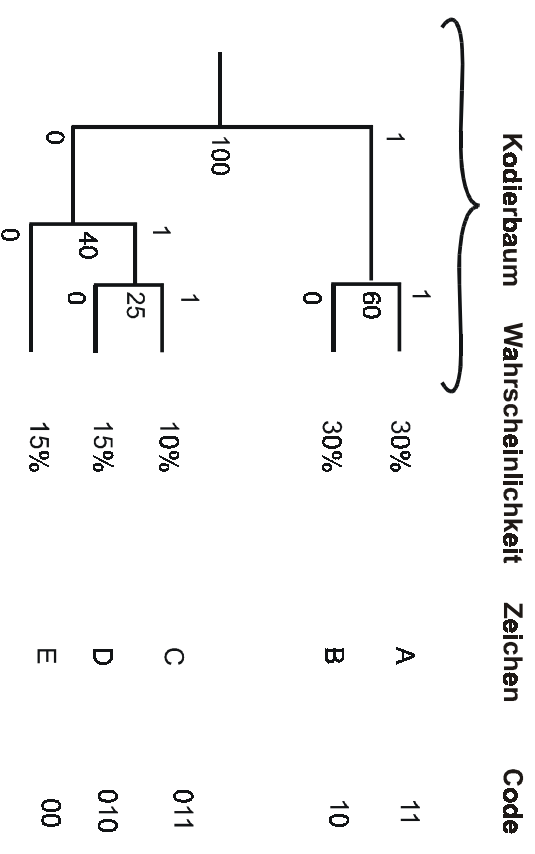

A Graduate Course on Multimedia Technology	© Wolfgang Effelsberg, Ralf Steinmetz	2. Compression, Part a	Za-12
---	--	---------------------------	-------

Huffman Code, why is it optimal?

Characters with higher probabilities are closer to the root of the tree and thus have shorter codeword lengths; thus it is a good code. It is even the best possible code!

Reason:

The length of an encoded string equals the weighted outer path length of the Huffman tree.

To compute the “weighted outer path length“ we first compute the product of the weight (frequency counter) of a leaf node with its distance from the root. We then compute the sum of all these values over the leaf nodes. This is obviously the same as summing up the products of each character’s codeword length with its frequency of occurrence.

No other tree with the same frequencies attached to the leaf nodes has a smaller weighted path length than the Huffman tree.

A Graduate Course on Multimedia Technology	© Wolfgang Effelsberg, Ralf Steinmetz	2. Compression, Part a	Za-13
---	--	---------------------------	-------

Sketch of the Proof

With the same building process another tree could be constructed but without always combining the two nodes with the minimal frequencies. We can show by induction that no other such strategy will lead to a smaller weighted outer path length than the one that combines the **minimal** values in each step.

A Graduate Course on Multimedia Technology	© Wolfgang Effelsberg, Ralf Steinmetz	2. Compression, Part a	Za-14
---	--	---------------------------	-------

Decoding Huffman Codes (1)

An obvious possibility is to use the TRIE:

1. Read the input stream sequentially and traverse the TRIE until a leaf node is reached.
2. When a leaf node is reached, output the character attached to it.
3. When reading the next bit, start again at the root of the TRIE.

Observation:

The input bit rate is constant, but the output character rate is variable.

A Graduate Course on Multimedia Technology	© Wolfgang Effelsberg, Ralf Steinmetz	2. Compression, Part a	Za-15
---	--	---------------------------	-------

Decoding Huffman Codes (2)

As an alternative we can use a **decoding table**.

Creation of the decoding table:

- If the longest codeword has L bits the table has 2^L entries.
- Let c_i be the codeword for character s_i . Let c_i have l_i bits. We then create 2^{L-l_i} entries in the table. In each of these entries the first l_i bits are equal to c_i , and the remaining bits take on all possible $L-l_i$ binary combinations.
- At all these addresses of the table we enter s_i as the character recognized, and we will remember l_i as the length of the codeword.

A Graduate Course on Multimedia Technology	© Wolfgang Effelsberg, Ralf Steinmetz	2. Compression, Part a	Za-16
---	--	---------------------------	-------

Decoding with the Table (3)

Algorithm Table-Based Huffman Decoder

1. Read L bits from the input stream into a buffer.
2. Use the buffer as the address into the table and output the recognized character s_i .
3. Remove the first l_i bits from the buffer and pull in the next l_i bits from the input bit stream.
4. Continue with step 2.

Observation

- Table-based Huffman decoding is fast.
- The output character rate is constant, but the input bit rate is variable.

A Graduate Course on Multimedia Technology	© Wolfgang Effelsberg, Ralf Steinmetz	2. Compression, Part a	Za-17
---	--	---------------------------	-------

Huffman Code, Comments

- A very good code for many practical purposes.
- Can only be used when the frequencies (or probabilities) of the characters are known in advance.
- Variant: Determine the character frequencies separately for each new document and store/transmit the code tree/table with the data.
- Note that a loss in “optimality” comes from the fact that each character must be encoded with a *fixed* number of bits, and thus the codeword lengths do not match the frequencies exactly (consider a code for three characters A, B and C, each occurring with a frequency of 33 %).

A Graduate Course on Multimedia Technology	© Wolfgang Effelsberg, Ralf Steinmetz	2. Compression, Part a	Za-18
---	--	---------------------------	-------

Lempel-Ziv Code

Lempel-Ziv codes are an example of the large group of dictionary-based codes.

Dictionary: A table of character strings which is used in the encoding process.

Example

The word "lecture" is found on page x_4 , line y_4 of the dictionary. It can thus be encoded as (x_4, y_4) .

A sentence such as „this is a lecture“ can then be encoded as a sequence of tuples (x_1, y_1) (x_2, y_2) (x_3, y_3) (x_4, y_4) .

A Graduate Course on Multimedia Technology	© Wolfgang Effelsberg, Ralf Steinmetz	2. Compression, Part a	Za-19
--	---------------------------------------	------------------------	-------

Dictionary-Based Coding Techniques

Static techniques:

The exists before a string is encoded and is not changed, neither in the encoding nor in the decoding process.

Dynamic techniques:

The dictionary is created "on the fly" during the encoding process, at the sending (and sometimes also at the receiving) side.

Lempel and Ziv have proposed an especially brilliant dynamic, dictionary-based technique (1977). Variants of this techniques are used very widely today for lossless compression. An example is LZW (Lempel/Ziv/Welch) which is invoked with the Unix **compress** command.

The well-known TIFF format (Tag Image File Format) is also based on Lempel-Ziv coding.

A Graduate Course on Multimedia Technology	© Wolfgang Effelsberg, Ralf Steinmetz	2. Compression, Part a	Za-20
--	---------------------------------------	------------------------	-------

Ziv-Lempel Coding, the Principle

Idea (pretty bright!)

The current piece of the message can be encoded as a reference to an earlier (identical) piece of the message. This reference will usually be shorter than the piece itself.

As the message is processed, the dictionary is created dynamically.

LZW Algorithm

```
InitializeStringTable();
WriteCode(ClearCode);
 $\omega$  = the empty string;
for each character in string {
    K = GetNextCharacter();
    if  $\omega$  + K is in the string table {
         $\omega$  =  $\omega$  + K /* String concatenation*/
    } else {
        WriteCode(CodeFromString( $\omega$ ));
        AddTableEntry( $\omega$  + K);
         $\omega$  = K;
    }
}
WriteCode(CodeFromString( $\omega$ ));
```

A Graduate Course on Multimedia Technology	© Wolfgang Effeisberg, Ralf Steinmeiz	2. Compression, Part a	2a-21
---	--	---------------------------	-------

LZW, Example 1, Encoding

Alphabet: X = {A, B, C}

Message: ABABCBBABAB

DICTIONARY	
Index	Entry
0	
1	A
2	B
3	C

Encoded message: 1 2 4 3 5 8

A Graduate Course on Multimedia Technology	© Wolfgang Effeisberg, Ralf Steinmeiz	2. Compression, Part a	2a-22
---	--	---------------------------	-------

LZW Algorithm: Decoding (1)

Note that the decoding algorithm also creates the dictionary dynamically, the dictionary is not transmitted!

```
while ( (Code=GetNextCode () != EofCode) {
    if (Code == ClearCode)
    {
        InitializeTable ();
        Code = GetNextCode ();
        if (Code==EofCode)
            break;
        WriteString (StringFromCode (Code));
        OldCode = Code;
    } /* end of ClearCode case */
    else
    {
        if (IsInTable (Code))
            WriteString ( StringFromCode (Code) );
        AddStringToTable (StringFromCode (OldCode) +
            FirstChar (StringFromCode (Code)));
        OldCode = Code;
    }
}
```

A Graduate Course on Multimedia Technology	© Wolfgang Effelsberg, Ralf Steinmetz	2. Compression, Part a	Za-23
---	--	---------------------------	-------

LZW Algorithm: Decoding (2)

```
else
    { /* codes in not in table */
        OutString = StringFromCode (OldCode) +
            FirstChar (StringFromCode (OldCode));
        WriteString (OutString);
        AddStringToTable (OutString);
        OldCode = Code;
    }
}
```

A Graduate Course on Multimedia Technology	© Wolfgang Effelsberg, Ralf Steinmetz	2. Compression, Part a	Za-24
---	--	---------------------------	-------

LZW, Example 2, Encoding (1)

Our alphabet is {A,B,C,D}. We encode the string ABACABA. In the first step we initialize the code table:

- 1 = A
- 2 = B
- 3 = C
- 4 = D

We read A from the input. We find A in the table and keep A in the buffer. We read B from the input into the buffer and now consider AB. AB is not in the table, we add AB with index 5, write 1 for A into the output and remove A from the buffer. The buffer only contains B now. Next, we read A, consider BA, add BA as entry 6 into the table and write 2 for B into the output, etc.

A Graduate Course on Multimedia Technology	© Wolfgang Effelsberg, Ralf Steinmetz	2. Compression, Part a	Za-25
---	--	---------------------------	-------

LZW, Example 2, Encoding (2)

At the end the code table is

- 1 = A
- 2 = B
- 3 = C
- 4 = D
- 5 = AB
- 6 = BA
- 7 = AC
- 8 = CA
- 9 = ABA.

The output data stream is 1 2 1 3 5 1.

Note that only the initial table is transmitted! The decoder can construct the rest of the table dynamically.

In practical applications the size of the code table is limited. The actual size is a trade-off between coding speed and compression rate.

A Graduate Course on Multimedia Technology	© Wolfgang Effelsberg, Ralf Steinmetz	2. Compression, Part a	Za-26
---	--	---------------------------	-------

LZW, Properties

- The dictionary is created dynamically during the encoding and decoding process. It is neither stored nor transmitted.
- The dictionary adapts dynamically to the properties of the character string.
- With length N of the original message, the encoding process is of complexity $O(N)$. With length M of the encoded message, the decoding process is of complexity $O(M)$. These are thus very efficient processes. Since several characters of the input alphabet are combined into one character of the code, $M \leq N$.

A Graduate Course on Multimedia Technology	© Wolfgang Effelsberg, Ralf Steinmetz	2. Compression, Part a	Za-27
---	--	---------------------------	-------

Typical Compression Rates

Typical examples of file sizes in % of the original size

Type of file	Encoded with Huffman	Encoded with Lempel-Ziv
C source code	65 %	45 %
machine code	80 %	55 %
Text	50 %	30 %

A Graduate Course on Multimedia Technology	© Wolfgang Effelsberg, Ralf Steinmetz	2. Compression, Part a	Za-28
---	--	---------------------------	-------

Arithmetic Coding

From an information theory point of view, the Huffman code is not quite optimal since a codeword must always consist of an integer number of bits even if this does not correspond exactly to the frequency of occurrence of the character. **Arithmetic coding** solves this problem.

Idea

An entire message is represented by a *floating point number* out of the interval $[0, 1)$. For this purpose the frequency of the next symbol. Each new sub-interval represents one symbol. When the process is completed the shortest floating point number contained in the target interval is chosen as the representative for the message.

A Graduate Course on Multimedia Technology	© Wolfgang Effelsberg, Ralf Steinmetz	2. Compression, Part a	Za-29
---	--	---------------------------	-------

Arithmetic Coding, the Algorithm

Algorithm Arithmetic Encoding

1. Begin in front of the first character of the input stream, with the current interval set to $[0, 1)$.
2. Read the next character from the input stream. Subdivide the current interval according to the frequencies of all characters of the alphabet. Select the subinterval corresponding to the current character as the next current interval.
3. If you reach the end of the input stream or the end symbol, go to step 4. Otherwise go to step 2.
4. From the current (final) interval, select the floating point number that you can represent in the computer with the smallest number of bits. This number is the encoding of the string.

A Graduate Course on Multimedia Technology	© Wolfgang Effelsberg, Ralf Steinmetz	2. Compression, Part a	Za-30
---	--	---------------------------	-------

Arithmetic Coding, the Decoding Algorithm

Algorithm Arithmetic Decoding

1. Subdivide the interval $[0, 1)$ according to the character frequencies, as described in the encoding algorithm, up to the maximum size of a message.
2. The encoded floating point number uniquely identifies one particular subinterval.
3. This subinterval uniquely identifies one particular message. Output the message.

A Graduate Course on Multimedia Technology	© Wolfgang Effelsberg, Ralf Steinmetz	2. Compression, Part a	Za-31
---	--	---------------------------	-------

Arithmetic Coding, Example

Alphabet = $\{A, B, C\}$

Frequencies (probabilities):

$$p(A) = 0.2;$$

$$p(B) = 0.3;$$

$$p(C) = 0.5$$

Messages: ACB AAB (maximum size of a message is 3).

Encoding of the first block:

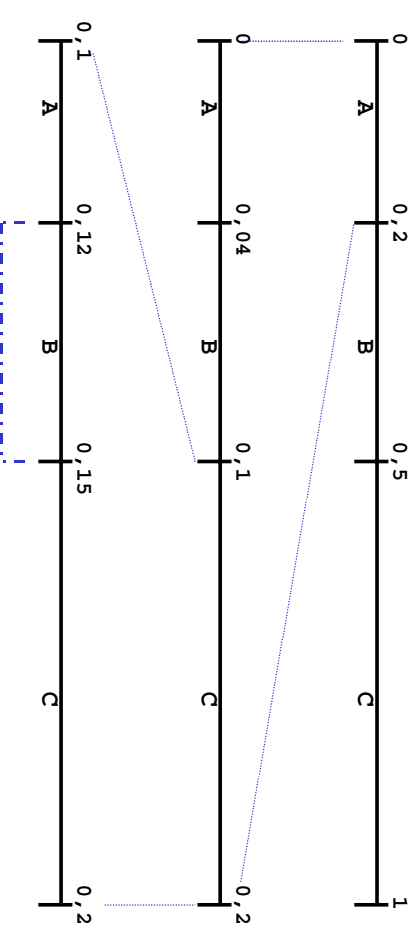

Final interval: $[0.12; 0.15)$ choose e.g. 0.12

A Graduate Course on Multimedia Technology	© Wolfgang Effelsberg, Ralf Steinmetz	2. Compression, Part a	Za-32
---	--	---------------------------	-------

Arithmetic Coding, Properties

- The encoding depends on the probabilities (frequencies) of the characters. The higher the frequency, the larger the subinterval; the smaller the number of bits needed to represent it.
- The code length reaches the theoretical optimum: The number of bits used for each character need not be an integer. It can approach the real probability better than with the Huffman code.
- There are several possibilities to terminate the encoding process:
 - The length of each block is known to sender and receiver.
 - There is a fixed number of bits of the mantissa (known to sender and receiver).

A Graduate Course on Multimedia Technology	© Wolfgang Effelsberg, Ralf Steinmetz	2. Compression, Part a	Za-33
---	--	---------------------------	-------

Arithmetic Coding, Problems

- The precision of floating point numbers is machine-dependent. Overflow and underflow can happen.
- Decoding can only begin after the full number has been received. The number can have many bits in the mantissa.
- One bit error destroys the entire message.

A Graduate Course on Multimedia Technology	© Wolfgang Effelsberg, Ralf Steinmetz	2. Compression, Part a	Za-34
---	--	---------------------------	-------